

WSMS01 **STABILIGHT** Technology

HIGH STABILITY, HIGH BRIGHTNESS WHITE LED SPOTLIGHT FOR MACHINE VISION APPLICATIONS

FEATURES

- **ENVIRONMENTALLY SEALED** - Pyrex lense with O ring seal protects the LED array from harsh industrial conditions. All circuitry is potted for mechanical and electrical stability.
- **STABILIGHT TECHNOLOGY** - Proprietary circuitry maintains a constant light output. By monitoring the LED array and rejecting unwanted power supply noise, the intensity of the spotlight is controlled, providing steady pixel counts.
- **POWER SUPPLY** - Special power supplies are not required for most applications. Due to the internal circuitry, readily available regulated power supplies are adequate.
- **QUICK CONNECTORS** - Industry standard, environmentally sealed connectors eliminate the need for custom extension cables and connectors. Multiple spotlights may easily be connected to one power supply.
- **WHITE - HIGH INTENSITY** - Super bright, white LED rather than RGB arrays provide a stable output with a narrow, well focused beam. Well suited for color applications.
- **MOUNTING** - Standard 1/4"- 20 threaded mounting holes easily adapt the spotlight to adjustable mounts.

Dimensions

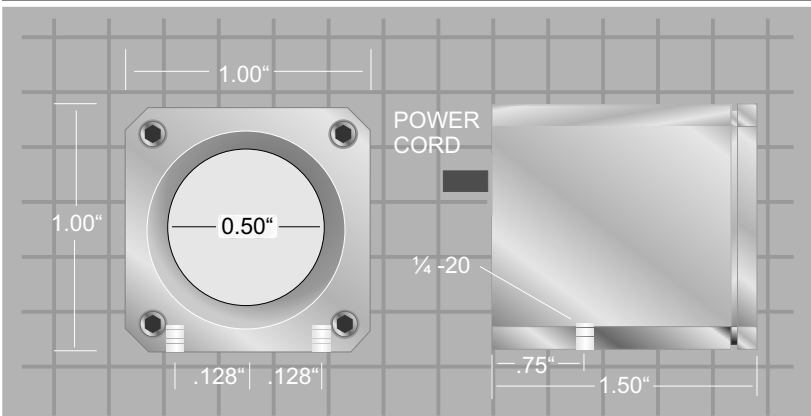

Specifications

Housing	Anodized Aluminum
Lense	Pyrex (polycarbonate)*
Power Cord	6FT Yellow PVC Jacketed
Quick Connector	Mini Change 4P Series
Input Voltage	24 Vdc +/- 1 Volt
Input Current	40 ma
Input Ripple	1 Volt P-P @ 50/60 Hz Max
Noise Rejection	30 Db to 10 KHz
Operating Temp	32 - 105 Deg F
LED Color Temp	Cool White 8000 Deg
LED Intensity	5000 mcd / LED

Typical Beam Spread

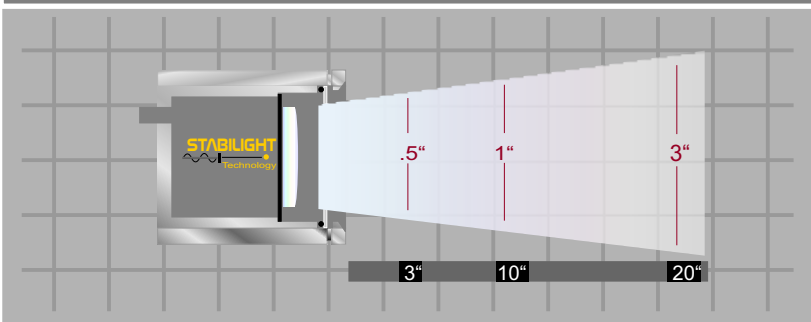

Wiring Diagram



Specifications subject to change without notice

* - Polycarbonate Lense Optional